

Great idea for spring and summer

Peaked cap for baby

Materials

- Jersey/Stretch fabric, 20 cm
- Hobby interlining, 13 cm

- Iron the hobby interlining onto a piece of fabric large enough to make 2 peaks.
- Cut 2 peaks in the fabric with hobby interlining
- Cut 2 cap pieces in fabric

Note: Place the pattern on the fold. There is 1 cm seam allowance

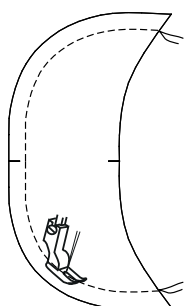

1. Sew 2 peak pieces together (1 cm seam allowance). Trim the seam allowance along the curved edge to 0.3-0.5 mm. Turn the peak to the right side. Press. Topstitch 0.5 cm from the edge all the way around the peak.

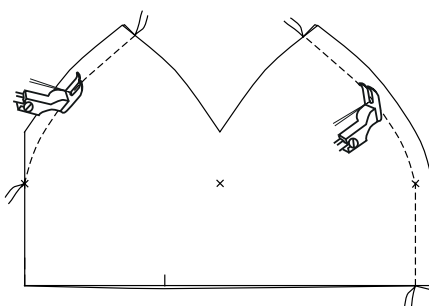

2. Fold one cap piece. Stitch as illustrated. Press. This piece is the right side of the cap on the outside.

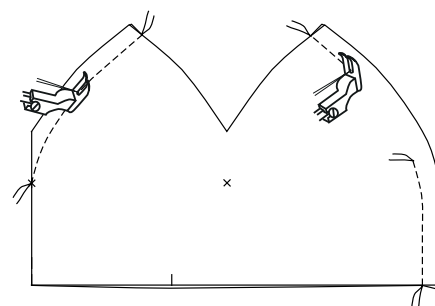

3. Make a second cap piece, leaving a gap at centre back for turning. This cap piece is the cap lining.

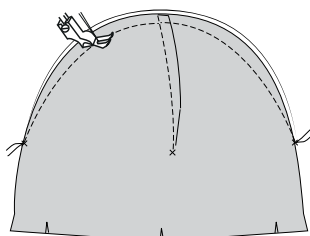

4. Stitch the seam at the top of the cap on the outside cap piece and the cap lining. Align the seam lines.

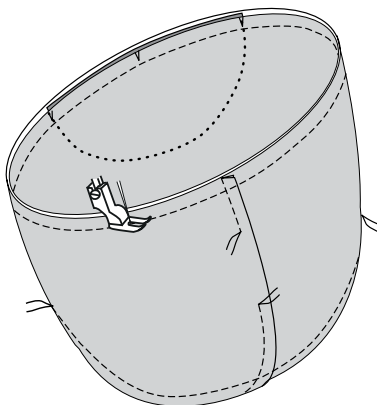

5. Insert the peak between the notches on the outside cap. Sew into place (0.7 cm seam allowance). Lay the cap lining and outside cap piece together, right sides facing. Align the centre back seam. Sew the lower edge of the cap (1 cm seam allowance).

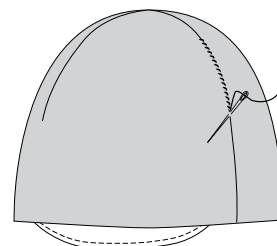

6. Turn right side out via the gap. To close the gap, blind stitch by hand. Press the lower edge of the cap.

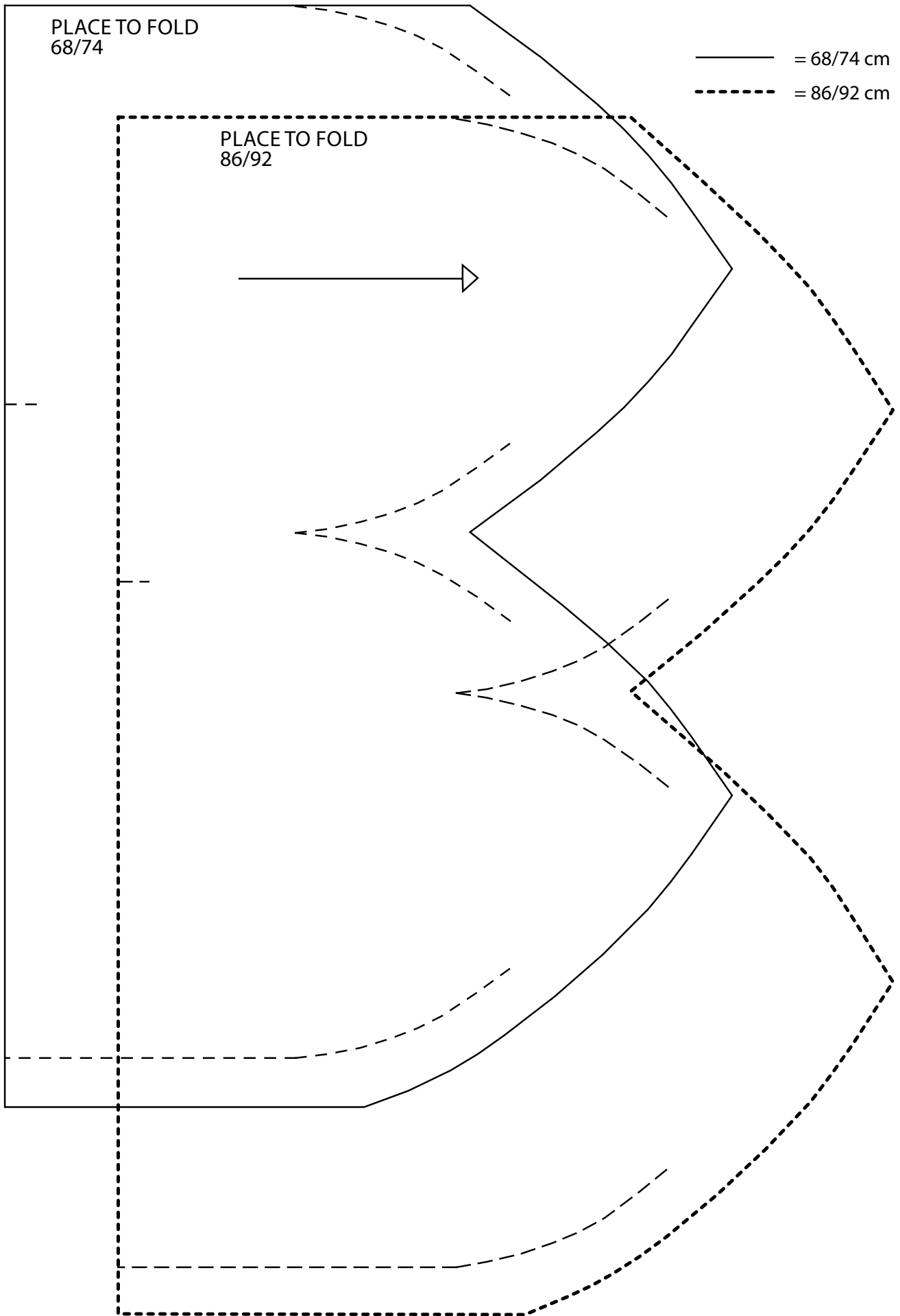

———— = 68/74 cm

- - - - - = 86/92 cm

