

A cosy idea for autumn and winter

# Neck Warmer

## Materials

- Jersey, 50 cm
- Pattern paper

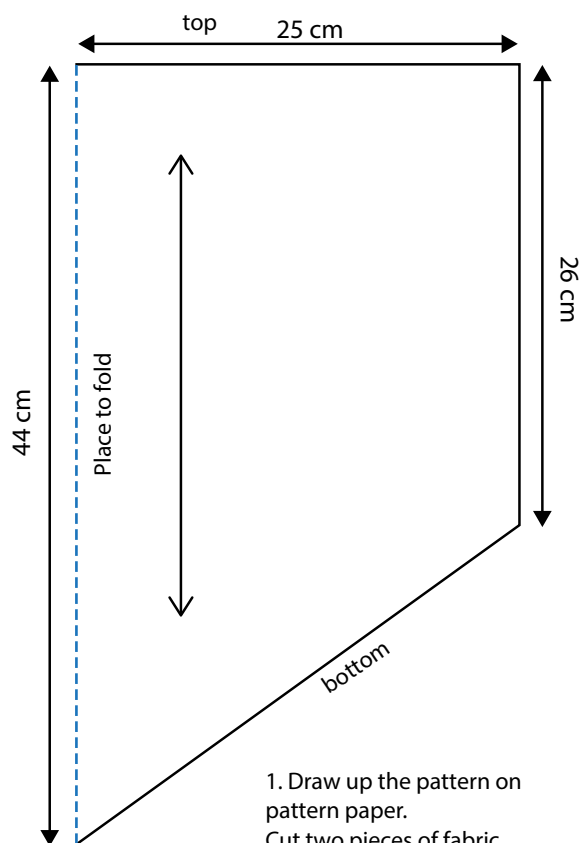

1. Draw up the pattern on pattern paper.  
Cut two pieces of fabric.

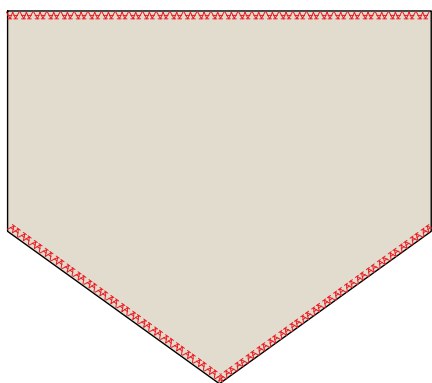

2. Lay the two pieces of fabric together, right sides facing.  
Sew the seams at the top and bottom.  
Use a stretch stitch or overlock.

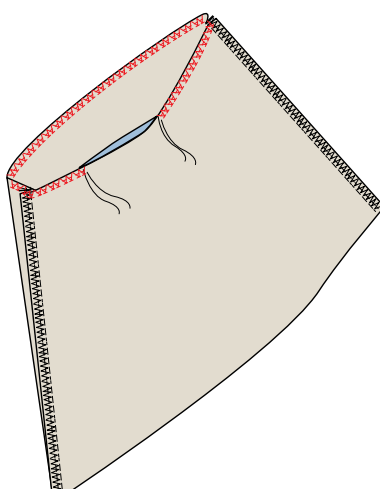

3. Fold one side over onto the other, right sides facing. Sew side seam, adjust to fit. Leave about a 5 cm gap for turning.

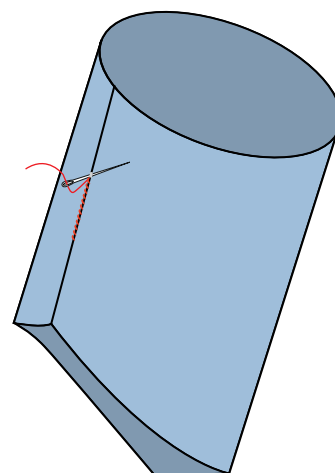

4. Turn the neck warmer to the right side.  
Hand-stitch the gap to close. Press.